

FLEXIBLE COUPLING ALC-AT

M 1501 340 E-EN-2008-09

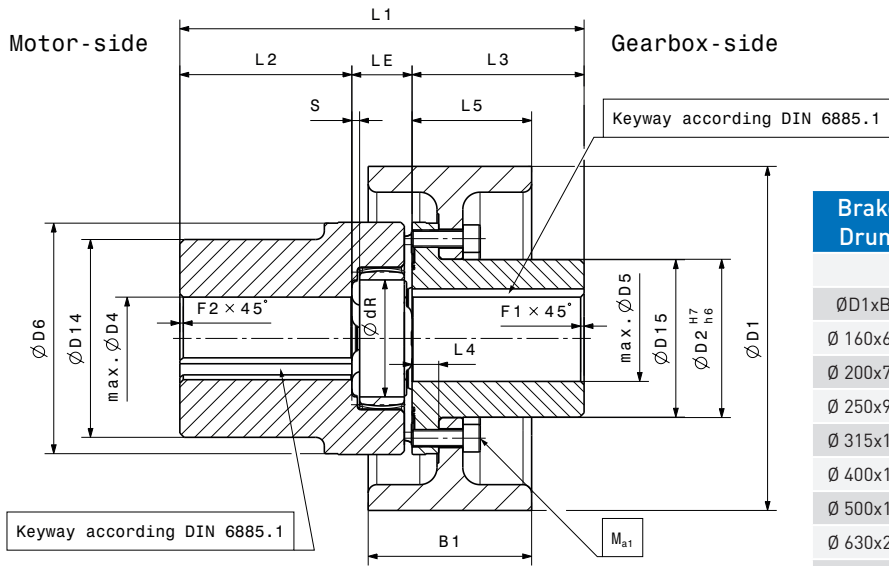

Brake Drum	Absolute dimension L5 in regards to coupling and drum size									
	38	42	48	55	65	75	90	100	110	125
ØD1xB1	L5	L5	L5	L5	L5	L5	L5	L5	L5	L5
Ø 160x60	44,5									
Ø 200x75	52,0	54,0	54,0	58,0						
Ø 250x95	60,5	65,5	65,5	69,5	69,5	72,5				
Ø 315x118		75,5	75,5	81,5	81,5	84,5	85,5			
Ø 400x150				96,5	96,5	99,5	100,5	105,5	106,5	
Ø 500x190						123,5	124,5	129,5	130,5	134,5
Ø 630x236							145,5	150,5	151,5	155,5
Ø 710x265									169,0	173,0

Brake Disc	Weight, moment of inertia and max. allowed braking torque in regards to coupling- and disc size										max rot. speed n _{max} in min ⁻¹
	38	42	48	55	65	75	90	100	110	125	
TB _{r,max} Nm	430	790	890	1000	1800	3840	7200	9900	14400	20000	
ØD1xB1	kg	kg	kg	kg	kg	kg	kg	kg	kg	kg	
	kgm ²	kgm ²	kgm ²	kgm ²	kgm ²	kgm ²	kgm ²	kgm ²	kgm ²	kgm ²	
Ø 160x60	3,4 0,016										4650
Ø 200x75	6,3 0,046	6,2 0,046	6,2 0,046	6,0 0,045							3750
Ø 250x95	12,4 0,141	12,3 0,141	12,2 0,141	12,1 0,140	11,9 0,140	11,6 0,139					3000
Ø 315x118		21,6 0,384	21,5 0,384	21,4 0,385	21,0 0,382	20,8 0,383	19,8 0,375				2350
Ø 400x150				40,5 1,182	40,2 1,182	39,8 1,180	38,8 1,175	38,2 1,173	37,0 1,167		1850
Ø 500x190						72,0 3,349	71,0 3,349	70,4 3,346	69,0 3,335	68,0 3,325	1450
Ø 630x236							139,0 10,336	138,0 10,321	136,0 10,280	135,0 10,280	1150
Ø 710x265									206,0 19,550	203,0 19,400	1050

Type ALC-AT	T _{kn} Nm	T _{kmax} Nm	Ø D4 max	Ø D5 max	Ø D6	ØD2 H7/h6	Ø D14	Ø D15	Ø dR	L1	L2	L3	L4	LE	S	F1 F2 x45°	DIN 912 -10.9	Z	Ma1	I w/o brake disc kgm ²	G kg
38	325	650	42	30	80	50	70	49,5	38	144	60	60	9,5	24	3	1,5	M8	8	35	0,002	2,3
42	450	900	50	38	95	60	80	59,5	46	166	70	70	11,5	26	3	1,5	M8	12	35	0,004	3,5
48	525	1050	55	42	105	68	90	67,5	51	178	75	75	11,5	28	3,5	2	M8	12	35	0,007	5
55	685	1370	65	48	120	78	105	77,5	60	200	85	85	15,5	30	4	2	M10	8	69	0,012	7,5
65	940	1880	70	55	135	92	115	91,5	68	235	100	100	15,5	35	4,5	2,5	M10	12	69	0,025	11
75	1920	3840	80	65	160	106	135	105,5	80	270	115	115	18,5	40	5	2,5	M12	15	120	0,055	18
90	3600	7200	100	85	200	140	160	139,5	100	315	135	135	19,5	45	5,5	3	M16	15	295	0,146	32
100	4950	9900	110	95	225	156	180	155	113	350	150	150	24,5	50	6	3	M16	15	295	0,256	44
110	7200	14400	125	110	255	176	200	175	127	375	160	160	25,5	55	6,5	3	M20	15	580	0,454	61
125	10000	20000	140	125	290	204	230	203	147	430	185	185	29,5	60	7	3	M20	15	580	0,885	91

When selecting the coupling assembly, setting and maintenance instructions have to be observed. Other drum diameters upon request. Other dimensions upon request. Individual balancing of coupling components available upon request. Axial fixing of coupling hub possible with set-screw above the key upon request. Weight and inertia indicated for max. bore ØD4 and Ø D5.